

# PIZZA PREPARATION TABLE

**Model: CPA60**

## 60" Pizza Preparation Refrigerator with Solid Doors

Heavy gauge #300 series stainless steel top, stainless steel front and end panels, aluminum interior.



### Options and Accessories

(upcharge and lead times may apply)

Stainless steel interior	Pan slides (larger section only)
Stainless steel back	Wire rod garnish rack
Overshelves (single or double)	Vision panel lid
Add'l epoxy-coated steel shelves	Door locks
Stainless steel shelves	Adjustable legs
Condensing unit on left (standard on right)	Front breathing
Drawer in lieu of half door above the condensing unit*	Special electrical requirements ( <i>consult factory</i> )

\*Drawer section above condensing unit holds (1) 12 x 20 x 6 pan  
Consult factory for other model configurations, options and accessories.

**Continental**<sup>®</sup>  
Refrigerator

Toll-Free: 800-523-7138  
Phone: 215-244-1400  
Fax: 215-244-9579

539 Dunksferry Road  
Bensalem, PA 19020  
[www.continentalrefrigerator.com](http://www.continentalrefrigerator.com)

Project Name:

Model Specified:

Location:

Item No:

Quantity:

AIA #:

SIS #:

### Standard Model Features

#### REFRIGERATION SYSTEM

- Performance-rated refrigeration system
- Environmentally-safe R-134a refrigerant
- Unique forced air design utilizes fans (approx. every 12") across the entire back of unit for even distribution of cold
- Automatic, electric condensate evaporator
- Non-corrosive, plasticized fin evaporator coil
- Easily serviceable, slide-out condensing unit
- Expansion valve system

#### CABINET ARCHITECTURE

- 2" non-CFC polyurethane foam insulation
- Smooth, polished chrome door handles
- Spring loaded, self closing doors
- Magnetic snap-in door gaskets
- Heavy-duty, epoxy-coated steel shelves
- 19" deep, full length nylon cutting board
- Insulated lid
- 5" casters

#### MODEL FEATURES

- Electronic controller w/digital display & hi-low alarm
- Ergonomically-friendly raised angle rail
- Built-in, off cycle defrost timer assures optimum coil defrost
- Refrigerated section w/door above the condensing unit
- Field rehingeable doors

*NOTE: CPA60 models come standard with a door above the condensing unit, a smaller width door (left section) and larger width door (center section). The option of having the doors located in the opposite sections **MUST** be indicated at the time of ordering. A drawer above the condensing unit is an option.*

APPROVAL:

## Model Specifications

### DIMENSIONAL DATA

Net Capacity (cu. ft.)	19 (538 cu l)
Width, Overall (in.)	60 (1524 mm)
Depth, Overall (in.) (incl. cutting board & bumpers)	36 7/8 (937 mm)
Height, Overall (in.) (incl. 5" casters)	39 7/16 (1002 mm)
Depth, Cutting Board (in.)	19 (483 mm)
Pan Capacity (pans supplied by others)	(8) 1/3
Shelf Area (sq. ft.)	7.1 (.7 sq m)
No. of Shelves	2
No. of Full Doors	2
No. of Half Doors	1
Interior Depth (in.)	27 3/8 (695 mm)
Interior Height (in.)	26 (660 mm)
Interior Height (in.) (above condenser)	12 1/2 (318 mm)
Interior Width (in.)	56 (1422 mm)

### REFRIGERANT DATA

Condensing Unit Size (H.P.)	1/2
Capacity (BTU/Hr)*	3100

### ELECTRICAL DATA

Voltage (int'l)	115/60/1 (220/50/1)
Fans	4
Total Amps (int'l)	13.0 (8.4)
10 ft. Cord/Plug [attached] (int'l)	Yes (No)

### SHIPPING DATA

Weight (lbs.)	451 (205 kg)
Height - Crated (in.)	43 3/4 (1111 mm)
Width - Crated (in.)	62 (1575 mm)
Depth - Crated (in.)	47 (1194 mm)

\* Rating @ +25°F evaporator, 90°F ambient  
 Figures in parentheses reflect metric equivalents rounded to the nearest whole unit.



Equipped with one NEMA-5-15P Plug  
 (varies by country)

## Model Plan Views

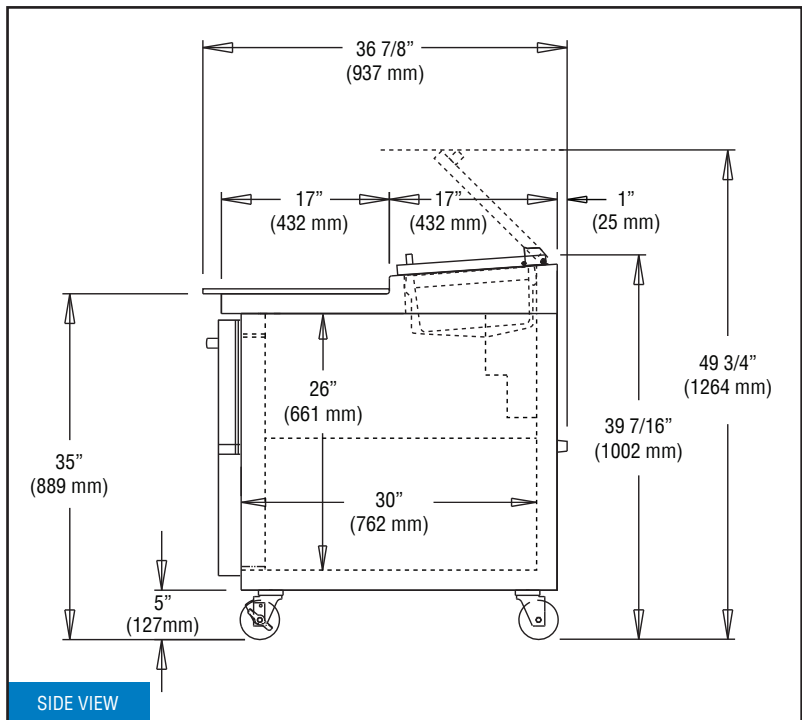
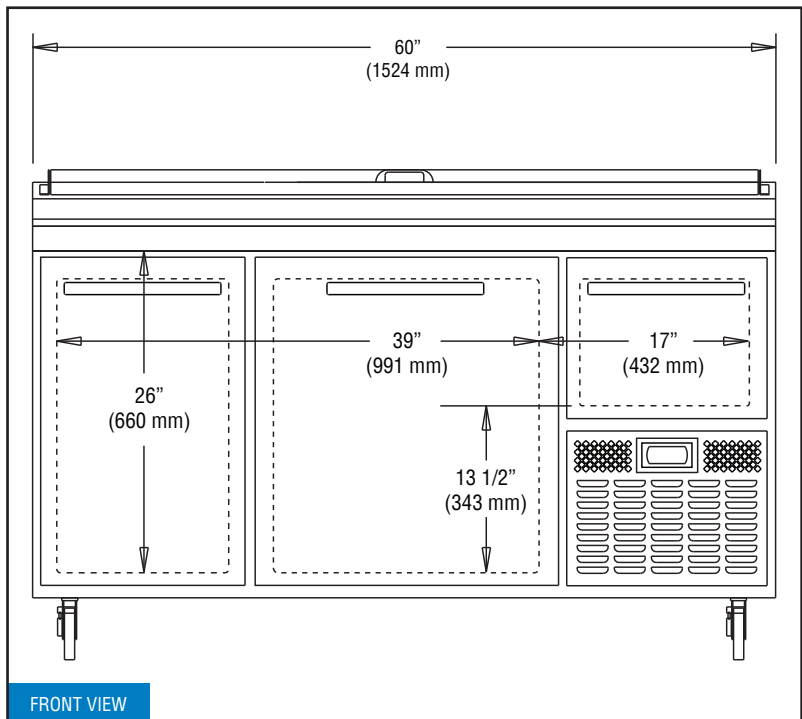

**IMPORTANT NOTE:** If the cabinet is located directly against a wall, a minimum clearance of 3" is required on sides, front and rear.

**Continental**  
 Refrigerator

Toll-Free: 800-523-7138  
 Phone: 215-244-1400  
 Fax: 215-244-9579

539 Dunkserry Road  
 Bensalem, PA 19020  
[www.continentalrefrigerator.com](http://www.continentalrefrigerator.com)

Due to our continued efforts in developing innovative products, specifications subject to change without notice.



MADE IN THE U.S.A.

© Copyright 2019, Continental Refrigerator.  
 A Division of National Refrigeration & Air Conditioning Products, Inc.