

GRIDDLE STAND REFRIGERATOR

Model: D36GN

Natural Refrigerant R-290 Model

36" Griddle Stand Refrigerator

Stainless steel exterior and interior, reinforced stainless steel work top with drip guard marine edge and stainless steel case back.



Options and Accessories

(upcharge and lead times may apply)

Flat top in lieu of marine edge	Integral heat shield top
16-gauge stainless steel top (flat or marine)	Cylinder locks
Top extensions (flat or marine edge)	Doors in lieu of drawers
Condensing unit left (standard on right)	Special electrical requirements (consult factory)

Consult factory for other model configurations, options and accessories.

Project Name:

Model Specified:

Location:

Item No:

Quantity:

AIA #:

SIS #:

Standard Model Features

REFRIGERATION SYSTEM

Performance-rated refrigeration system

Natural, environmentally-safe, high-efficiency R-290 refrigerant¹

Automatic, hot gas condensate evaporator

Non-corrosive, plasticized fin evaporator coil

Easily serviceable, front slide-out condensing unit

CABINET ARCHITECTURE

High density, non-CFC polyurethane foamed-in-place insulation

Easy glide, fully extendable drawers designed to hold 6" deep pans side-by-side

Smooth, polished chrome drawer handles

One-piece, snap-in magnetic drawer gaskets

Heavy-duty drawer track with built-in drawer safety clips

Drawers designed to hold 250 lb. capacity

4" casters on support plates

MODEL FEATURES

Electronic controller w/digital display & hi-low alarm

Front breathing

¹ R-290 refrigerant meets all federal and state regulatory requirements.

Continental[®]
Refrigerator

Toll-Free: 800-523-7138
Phone: 215-244-1400
Fax: 215-244-9579

539 Dunksferry Road
Bensalem, PA 19020
www.continentalrefrigerator.com

APPROVAL:

Model Specifications

DIMENSIONAL DATA

Net Capacity (cu. ft.)	6.5 (184 cu l)
Width, Overall (in.)	36 (914 mm)
Depth, Overall (in.) (incl. handles)	35 5/16 (897 mm)
Height, Overall (in.) (incl. 4" casters)	26 3/8 (670 mm)
No. of Drawers	2

REFRIGERANT DATA

Condensing Unit Size (H.P.)	1/5
Capacity (BTU/Hr)*	1620

ELECTRICAL DATA

Voltage (int'l)	115/60/1 (220/50/1)
Feed Wires (incl. ground)	3
Total Amps (int'l)	2.5 (1.9)
10 ft. Cord/Plug [attached] (int'l)	Yes (No)

SHIPPING DATA

Weight (lbs.)	360 (163 kg)
Height - Crated (in.)	44 (1118 mm)
Width - Crated (in.)	52 (1472 mm)
Depth - Crated (in.)	39 (991 mm)

DRAWER PAN DIVIDERS (supplied with model)

CM2-0682	2 (one per drawer)
----------	--------------------

See drawer pan configurations on right (**pans not supplied**). For other drawer pan configurations, consult factory.

TOP WEIGHT CAPACITY

Max. Top Weight Capacity (lbs.)	600 (272 kg)
---------------------------------	--------------

* Rating @ +25°F evaporator, 90°F ambient

Figures in parentheses reflect metric equivalents rounded to the nearest whole unit.



Equipped with one NEMA-5-15P Plug (varies by country)

Continental
Refrigerator

Toll-Free: 800-523-7138
Phone: 215-244-1400
Fax: 215-244-9579

539 Dunkserry Road
Bensalem, PA 19020
www.continentalrefrigerator.com

Due to our continued efforts in developing innovative products, specifications subject to change without notice.



Intertek

© Copyright 2019. Continental Refrigerator.

A Division of National Refrigeration & Air Conditioning Products, Inc.



MADE IN THE U.S.A.

Model Plan Views

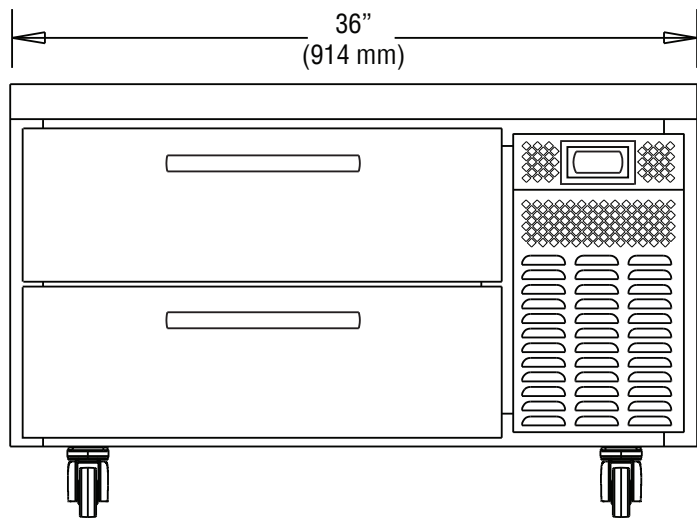

FRONT VIEW

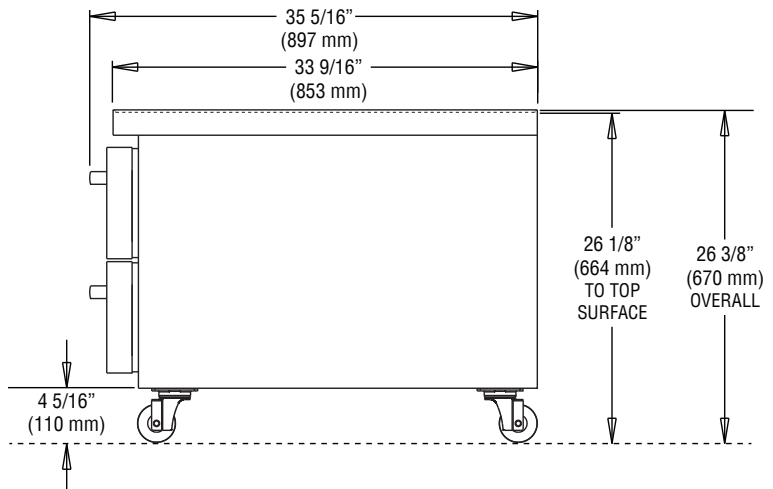

SIDE VIEW

Shown with (2) 12 x 20 x 6 pans and (2) 6 x 20 x 6 pans (**not supplied**).

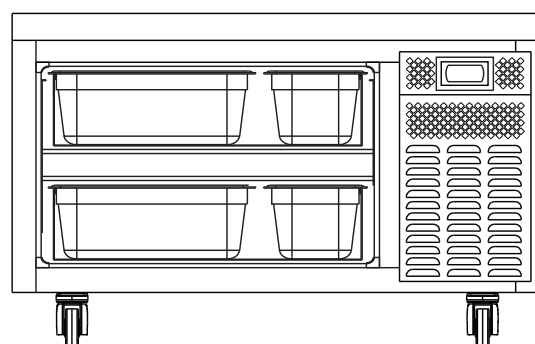

DRAWER PAN CONFIGURATION