

WORKTOP REFRIGERATOR

Model: SW48N

Natural Refrigerant R-290 Model

48" Worktop Refrigerator with Solid Doors



ENERGY STAR® Qualified Commercial Refrigerator

Stainless steel front, top and end panels, aluminum back and interior.



Options and Accessories

(upcharge and lead times may apply)

Stainless steel interior	Expansion valve system
Stainless steel back	Adjustable legs
Overshelves (single or double)	Door locks
Add'l epoxy-coated steel shelves	Special electrical requirements (consult factory)
Stainless steel shelves	

Consult factory for other model configurations, options and accessories.

Project Name:

Model Specified:

Location:

Item No:

Quantity:

AIA #:

SIS #:

Standard Model Features

REFRIGERATION SYSTEM

- Performance-rated refrigeration system
- Natural, environmentally-safe, high-efficiency R-290 refrigerant¹
- Automatic, hot gas condensate evaporator
- Non-corrosive, plasticized fin evaporator coil
- Easily serviceable, back mounted compressor

CABINET ARCHITECTURE

- 2" non-CFC polyurethane foam insulation
- Smooth, polished chrome door handles
- Spring loaded, self closing doors
- Magnetic snap-in door gaskets
- Heavy-duty, epoxy-coated steel shelves
- Completely enclosed, vented and removable case back
- 5" casters

MODEL FEATURES

- Electronic controller w/digital display & hi-low alarm
- Field rehingeable doors

¹ R-290 refrigerant meets all federal and state regulatory requirements.

Continental
Refrigerator

Toll-Free: 800-523-7138
Phone: 215-244-1400
Fax: 215-244-9579

539 Dunksferry Road
Bensalem, PA 19020
www.continentalrefrigerator.com

APPROVAL:

Model Specifications

DIMENSIONAL DATA

Net Capacity (cu. ft.)	13.4 (379 cu l)
Width, Overall (in.)	48 (1219 mm)
Depth, Overall (in.) (incl. handles & bumpers)	32 3/16 (818 mm)
Height, Overall (in.) (incl. 5" casters)	35 1/4 (895 mm)
Shelf Area (sq. ft.)	6.8 (.6 sq m)
No. of Shelves	2
No. of Doors	2
Interior Depth (in.)	See Drawing
Interior Height (in.)	26 1/4 (667 mm)
Interior Width (in.)	44 (1118 mm)

REFRIGERANT DATA

Condensing Unit Size (H.P.)	1/5
Capacity (BTU/Hr)*	1625

ELECTRICAL DATA

Voltage (int'l)	115/60/1 (220/50/1)
Total Amps (int'l)	2.46 (1.85)
10 ft. Cord/Plug [attached] (int'l)	Yes (No)

SHIPPING DATA

Weight (lbs.)	248 (112 kg)
Height - Crated (in.)	43 1/4 (1099 mm)
Width - Crated (in.)	56 (1422 mm)
Depth - Crated (in.)	37 1/4 (946 mm)

* Rating @ +25°F evaporator, 90°F ambient

Figures in parentheses reflect metric equivalents rounded to the nearest whole unit.



Equipped with one NEMA-5-15P Plug
(varies by country)

Continental
Refrigerator

Toll-Free: 800-523-7138
Phone: 215-244-1400
Fax: 215-244-9579

539 Dunkserry Road
Bensalem, PA 19020
www.continentalrefrigerator.com

Due to our continued efforts in developing innovative products, specifications subject to change without notice.



MADE IN THE U.S.A.

© Copyright 2019, Continental Refrigerator.
A Division of National Refrigeration & Air Conditioning Products, Inc.

Model Plan Views

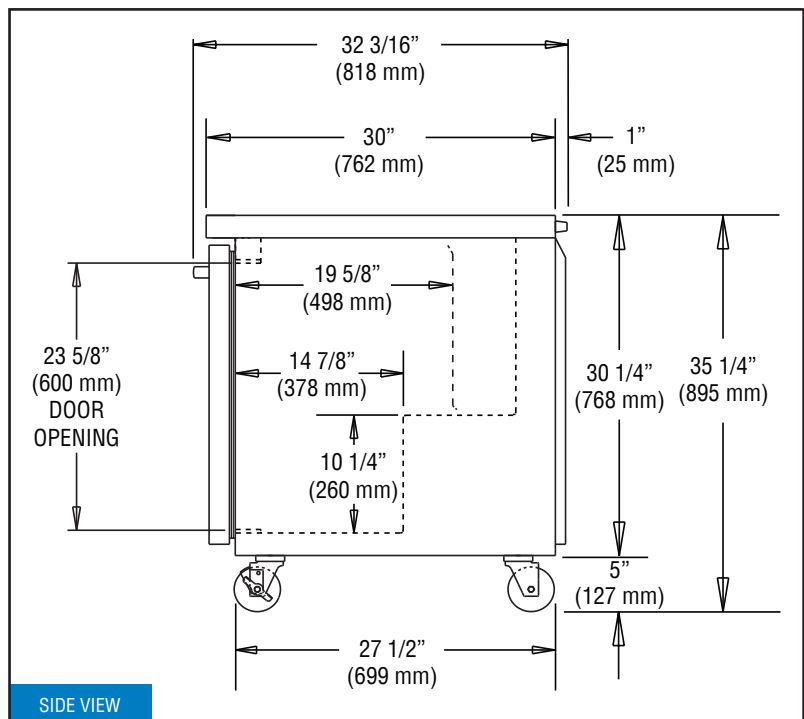
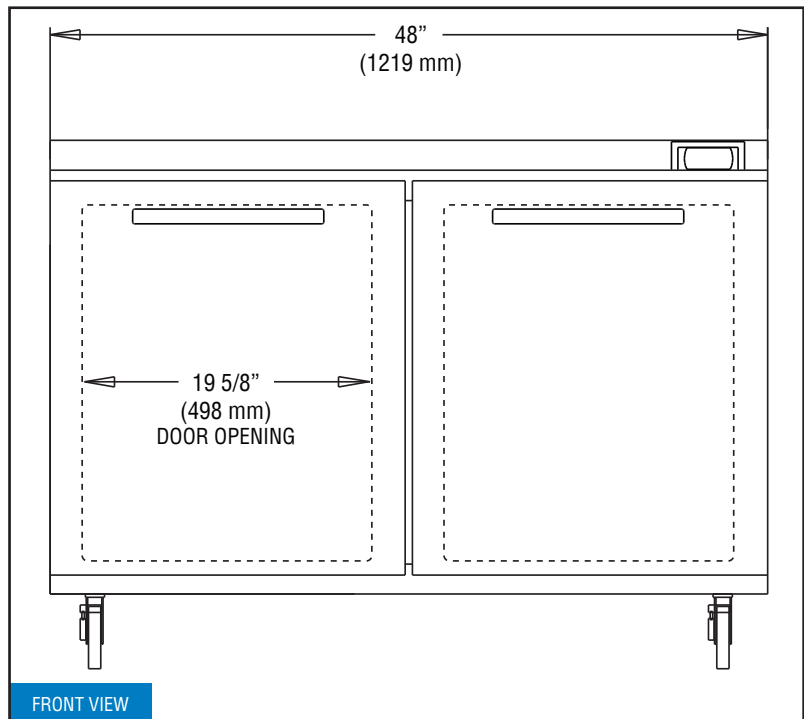

IMPORTANT NOTE: If the cabinet is located directly against a wall, a minimum clearance of 3" is required on sides, front and rear.